

# *Bravetti*

## **300 Watt 6 Speed Power Mixer**

Use and Care Instructions

Model EP565CH

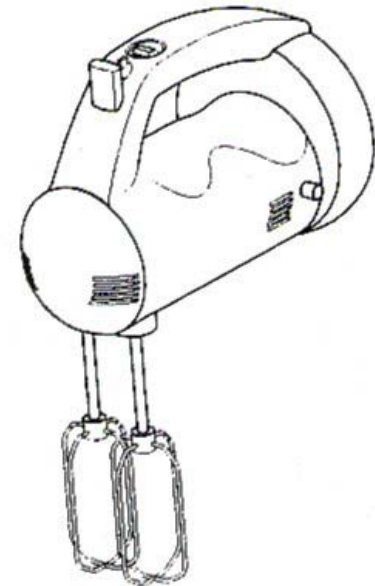

For information or technical assistance, call

U.S.: 1-800-798-7398

(Canada: 514-842-8691)

**EURO-PRO** Corporation

178 West Service Rd.

Champlain, NY 12919

# IMPORTANT SAFEGUARDS

When using electrical appliances, basic safety precautions should always be followed, including the following:

1. Read all instructions before using the appliance.
2. To protect against risk of electrical shock, do not put cord, plug or mixer in water or other liquid.
3. Close supervision is necessary when appliance is used by or near children.
4. Unplug appliance from outlet when not in use, before putting on or taking off parts, and before cleaning.
5. Avoid contact with moving parts at all times. Keep hands, hair, clothing, as well as spatulas and other utensils away from beaters during operation to prevent personal injury and/or damage to the mixer.
6. Do not operate any appliance with a damaged cord or plug or after the appliance malfunctions, or has been dropped or damaged in any manner. Return appliance to EURO-PRO Corporation for examination, repair or electric/mechanical adjustment.
7. The use of attachments not recommended or sold by **EURO-PRO** Corporation may cause fire, electric shock or injury.
8. Do not use outdoors.
9. Do not let cord hang over edge of table or counter or touch hot surfaces, including the stove.
10. Remove beaters, dough hooks and whisk from mixer before cleaning.
11. **DO NOT USE THIS APPLIANCE ON A STOVE.**
12. Do not use appliance for other than intended use.
13. The mixer is designed for intermittent use. It can be run for up to 10 minutes on Lo range speeds 1 - 3 without interruption. Do not operate for more than 30 seconds on Hi range speed 3. Allow the motor to cool afterwards.
14. To avoid injury by accidentally switching on the appliance when inserting the dough hooks, beaters, chopper and hand blender attachment, always set the switch to position 'OFF' and unplug the appliance before assembling or disassembling.
15. Use only on appropriate AC voltage outlets. (See rating label on bottom of appliance).

## IMPORTANT NOTICE

This appliance has a polarized plug (one blade is wider than the other). To reduce the risk of electric shock, this plug will fit in a polarized outlet only one way. If the plug does not fit fully in the outlet, reverse the plug. If it still does not fit, contact a qualified electrician. Do not modify the plug in any way.

## SAVE THESE INSTRUCTIONS

**THIS APPLIANCE IS FOR HOUSEHOLD USE ONLY**

**Bravetti**  
300 Watt 6 Speed Power Mixer

**Main Components**

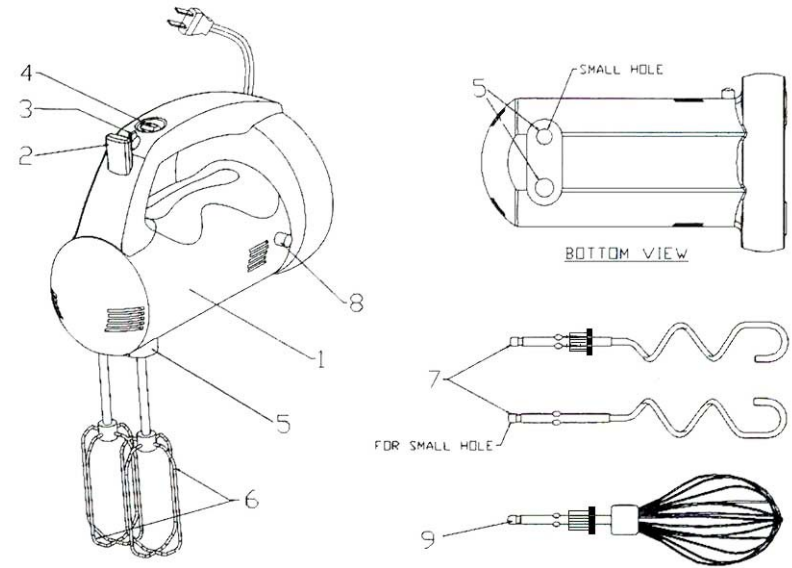

- |                           |                       |
|---------------------------|-----------------------|
| 1. Main Housing           | 6. Mixer Beaters (2)  |
| 2. Beater Release Button  | 7. Dough Hooks (2)    |
| 3. Speed Selector         | 8. Cord Rewind Button |
| 4. Range Selector Lo - Hi | 9. Whisk (1)          |
| 5. Beater Openings        |                       |

**CAUTION:** Do not pull with force on power cord or you will damage the rewinding feature and void warranty.

Congratulations! As the owner of a new **Bravetti** 6 speed hand mixer, you are about to use a very versatile and powerful kitchen mixing tool. You will enjoy 300 watts of power and six convenient speeds.

## INSTRUCTIONS FOR USE

Before using your **Bravetti** mixer for the first time, wash the beaters, dough hooks, whisk and bowl in warm, sudsy water. Rinse and dry thoroughly.

### TO USE HAND MIXER

#### A. To insert beaters, dough hooks or whisk (6,7, 9)

Make sure that the mixer is unplugged from power source and speed selector is set on 'OFF' (0) before inserting or removing beaters, dough hooks or whisk. Always insert the attachments (6,7,9) with the gear into the larger hole. (See illustration below.)

**Select the attachment according to the type of mix required.**

Beaters: (6) For liquid mixes such as creams, egg-whites, cookie doughs, etc.

Insert beaters (6) one at a time, by placing stem end of beaters into opening on bottom of mixer (5). Place beater with gear into the larger hole. (See illustration below.) Press beater in gently and rotate slightly until beater clicks into place. Gently tug on beaters to ensure they are secured properly.

Dough hooks: (7) For light doughs.

To insert dough hooks: Insert dough hooks (7) in the same way as beaters above. Always use both dough hooks. Never try to work with one beater and one dough hook at the same time.

Do not use dough hooks at low speeds as this may cause motor to overheat. When using dough hooks for heavy or thick dough, use only high speeds (Hi 1-3) from the beginning to prevent the motor from overheating (blocking).

Whisk: (9) The whisk is used to beat air into mixtures such as egg whites, yolks or cream. Insert the whisk into the large hole.

**IMPORTANT:** The beater, dough hook or whisk with the gear must be inserted into the larger opening.

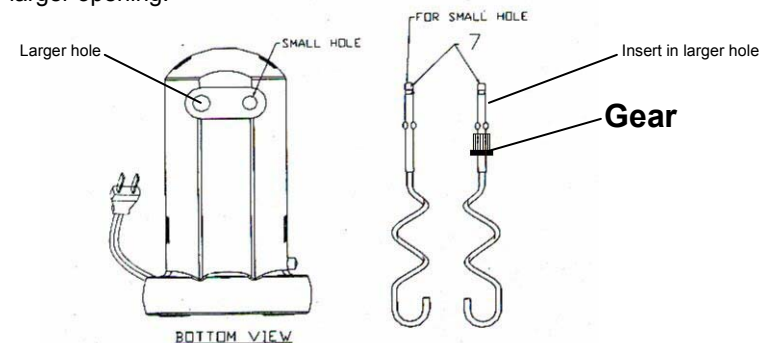

## To Operate Mixer

- Gently pull out the power cord from the main housing. Do not pull too hard or you may damage the auto-rewind function.
- Before plugging in the unit, fit the attachments necessary for the mixing operation to be carried out: Use beaters (6) to beat liquids such as creams, egg whites, cake and cookie mixes.
- ✎ Insert beaters (6) one at a time in beater openings (5) by pressing them gently upwards until they are fully fitted (a click will be heard).
- When finished, remove beaters by pressing beater release button (2). Use Dough Hooks (7): to mix light dough. Use whisk (9) to whip eggs, egg whites, etc.

**IMPORTANT:** The dough hook with the gear must go into the larger opening, otherwise the dough may overflow.

- When you have chosen the attachments to be used, plug the mixer in the outlet.
- Pick the mixer up and use your thumb to set the speed selector (3) to the setting you require and the Range Selector (4) :

-0: Off

### Lo Range

- 1: Low speed
- 2: Medium speed
- 3: High speed

### Hi Range

- 1: Low speed
- 2: Medium speed
- 3: High speed

- ✎ We suggest that you begin at Hi range speed 3 to prevent the motor from blocking. Do not operate at Hi range speed 3 for more than 30 seconds.
- ✎ Ensure that the beaters are completely free to move in your bowl.
- ✎ Return to setting 0 when you have finished mixing or to stop
- ✎ To remove the beaters, dough hooks or whisk (6, 7 or 9) from the main housing  
(1) press the release button (2): this button works only when the mixer is set to "0".
- ✎ Push the Cord winding button (8), the power cord **will** rewind automatically.

### Cleaning and Maintenance

- ✎ Ensure that the mixer is unplugged and switched "Off" (0) before cleaning.
- ✎ Clean the beaters, dough hooks and whisk (6, 7 & 9) in soapy warm water or the dishwasher,
- ✎ Use a damp cloth to clean the main housing.
- ✎ NEVER submerge the unit in water or any other liquid.

# Bravetti/EURO-PRO

## THREE (3) YEAR LIMITED WARRANTY

**EURO-PRO** CORPORATION warrants this product to be free from defects in material and workmanship for a period of three (3) years from the date of purchase when utilized for normal household use.

If your appliance fails to operate properly while in use under normal household conditions within the warranty period, return the complete appliance and accessories, freight prepaid to **EURO-PRO** Corporation, 178 West Service Rd., Champlain, N.Y. 12919. If the appliance is found by **EURO-PRO** to be defective in material or workmanship, **EURO-PRO** will repair or replace it free of charge. Proof of purchase date and \$5.00 to cover the cost of return shipping and handling must be included.\*

The liability of **EURO-PRO** Corporation is limited solely to the cost of the repair or replacement of the unit at our option. This warranty does not cover normal wear of parts and does not apply to any unit that has been tampered with or used for commercial purposes. This limited warranty does not cover damage caused by misuse, abuse, negligent handling or damage due to faulty packaging or mishandling in transit.

This warranty is extended to the original purchaser of the unit and excludes all other legal and/or conventional warranties. The responsibility of **EURO-PRO** Corporation if any, is limited to the specific obligations expressly assumed by it under the terms of the limited warranty. **In no event** is **EURO-PRO** Corporation liable for incidental or consequential damages of any nature whatsoever. Some states do not permit the exclusion or limitation of incidental or consequential damages, so the above may not apply to you.

This warranty gives you specific legal rights, and you may also have other rights which vary from state to state.

**\*Important: Carefully pack item to avoid damage in shipping. Be sure to include proof of purchase date and to attach tag to item before packing with your name, complete address and phone number with a note giving purchase information, model number and what you believe is the problem with item. We recommend you insure the package (as damage in shipping is not covered by your warranty). Mark the outside of your package "ATTENTION CUSTOMER SERVICE".**



.....

### OWNERSHIP REGISTRATION CARD

Please fill out and mail the product registration card within ten (10) days of purchase in order to validate the foregoing Limited Warranty. The registration will enable us to contact you in the unlikely event of a product safety notification. By returning this card you acknowledge to have read and understood the instructions for use, and warnings set forth in the accompanying instructions.

**RETURN TO EURO-PRO CORPORATION, 178 WEST SERVICE RD., CHAMPLAIN, N.Y. 12919**

\_\_\_\_\_  
Appliance model

\_\_\_\_\_  
Date purchased

\_\_\_\_\_  
Name of store

\_\_\_\_\_  
Owner's name

\_\_\_\_\_  
Address

\_\_\_\_\_  
City

\_\_\_\_\_  
State

\_\_\_\_\_  
Zip code